

AC600 Gearbox Assembly

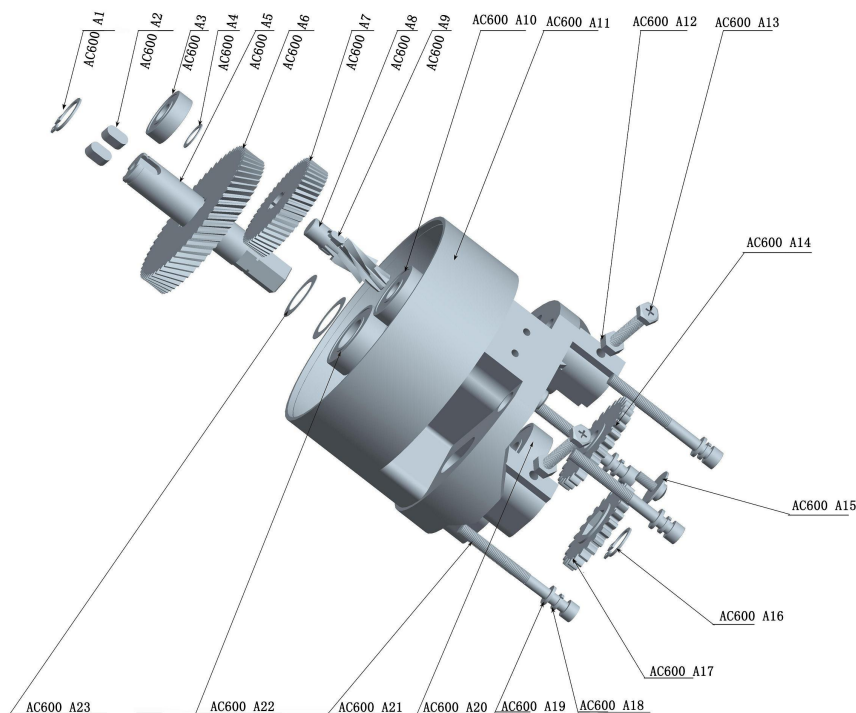

- AC600 A1: Check ring on shaft
- AC600 A2: Key
- AC600 A3: Bearing
- AC600 A4: Thin gasket
- AC600 A5: Shaft
- AC600 A6: Passive gear - shaft 2
- AC600 A7: Passive gear - shaft 1
- AC600 A8: shaft 1
- AC600 A9: Key
- AC600 A10: Bearing
- AC600 A11: Gearbox case
- AC600 A12: Nut
- AC600 A13: Screw
- AC600 A14: Intermediate gear
- AC600 A15: recessed panhead screw with springwasher & flat washer
- AC600 A16: Check ring on shaft
- AC600 A17: Hexagon transmission gear
- AC600 A18: spring washer
- AC600 A19: Flat washer
- AC600 A20: Bearing
- AC600 A21: Inner hexagon screw
- AC600 A22: Bearing
- AC600 A23: Thin gasket

AC600 Motor assembly & Brake disc component (excluding circuit)

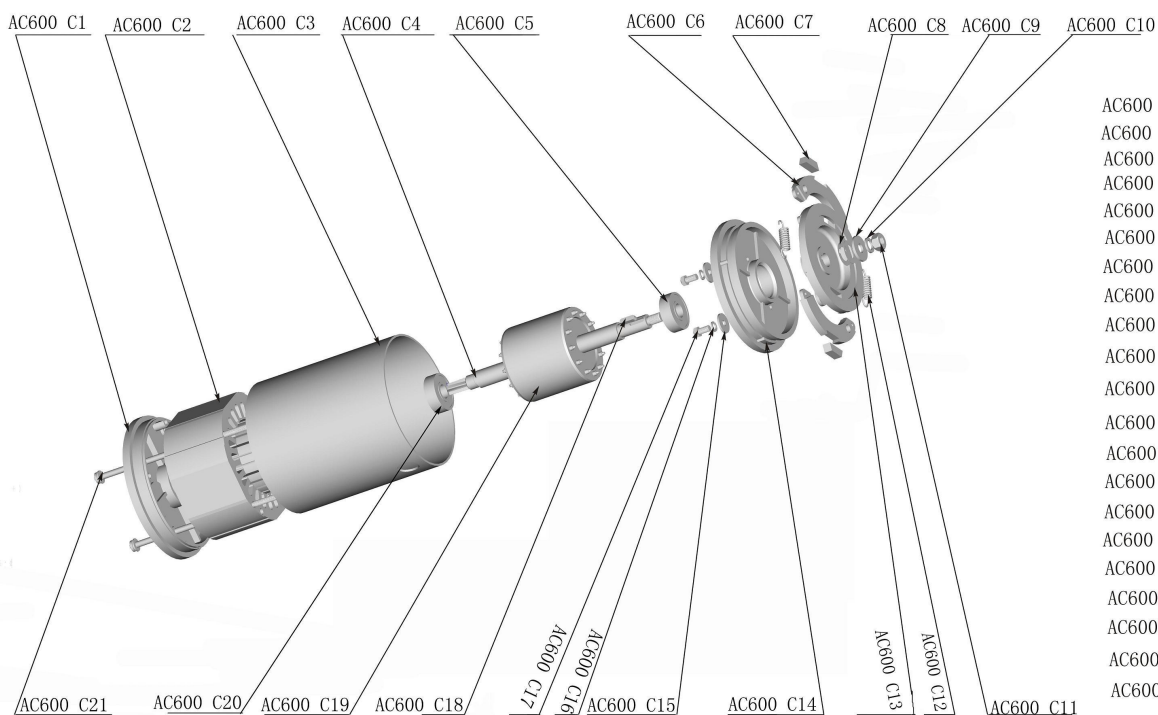

- AC600 C1: Front cover
- AC600 C2: Stator
- AC600 C3: Main case
- AC600 C4: Motor shaft
- AC600 C5: Bearing
- AC600 C6: Brake arm
- AC600 C7: Radial brake pads
- AC600 C8: Groove gasket
- AC600 C9: Flap gasket
- AC600 C10: Spring washer
- AC600 C11: Nut
- AC600 C12: Spring rashin
- AC600 C13: Brake disc
- AC600 C14: Rear cover
- AC600 C15: Flat washer
- AC600 C16: Spring washer
- AC600 C17: Cross recess head screw
- AC600 C18: Key
- AC600 C19: The rotor
- AC600 C20: Bearing
- AC600 C21: Lock screw

## AC600 Brake assembly & Electrical assembly(excluding circuit)

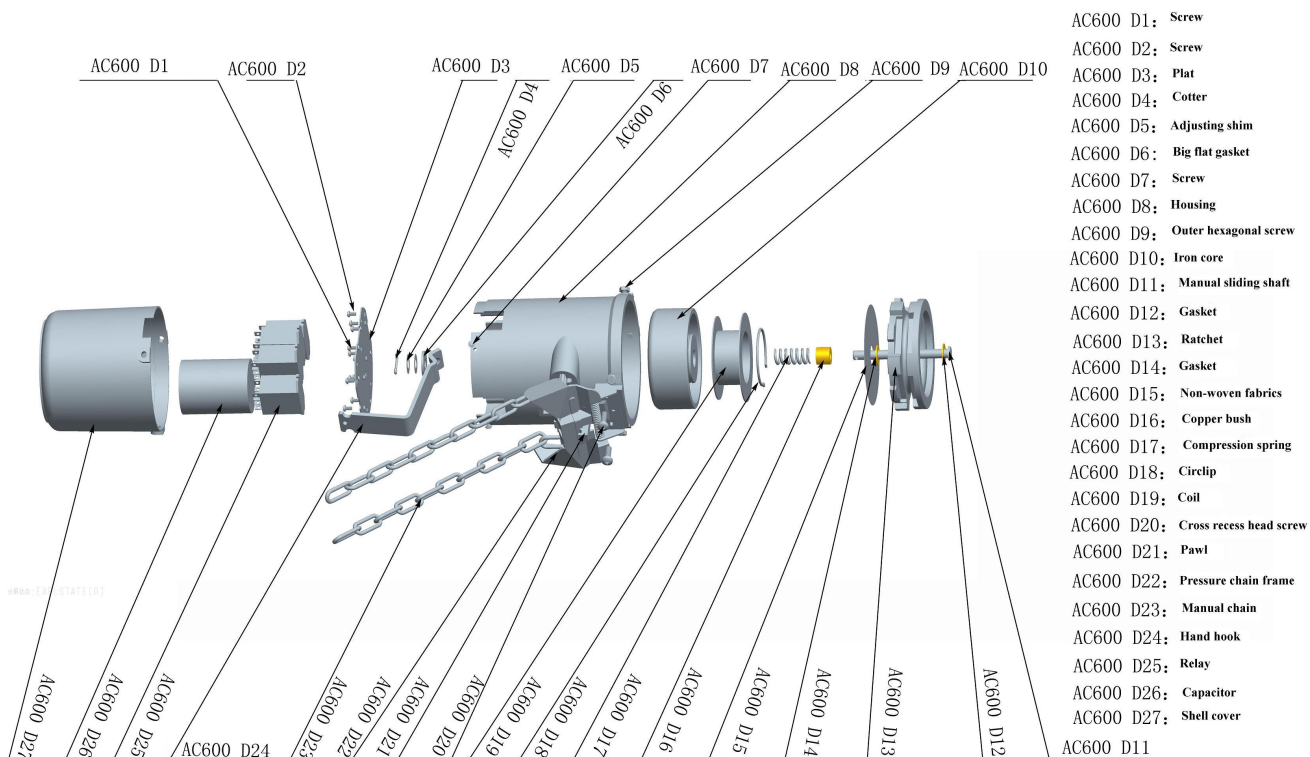

## AC600 Limit switch assembly (excluding circuit)

